

HULALA

H O M E

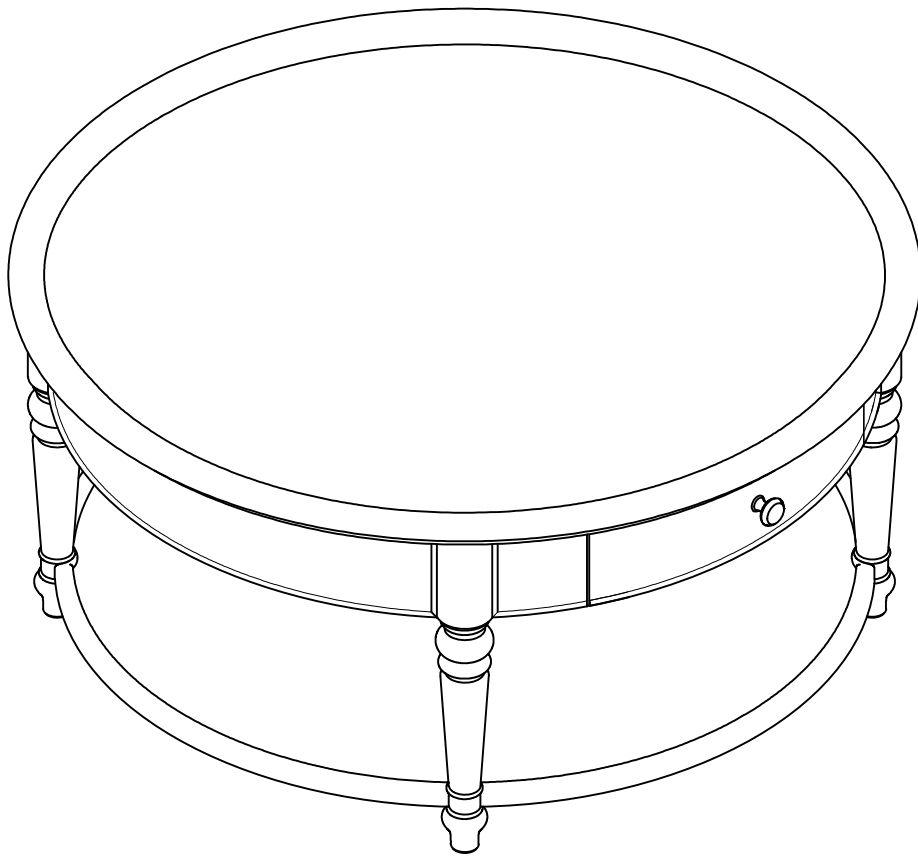

ITEM NO.CTTL1404

NOTE:

This brochure contains IMPORTANT safty info. Please read and keep for future reference.

MAINTAINANCE AND WARNING

- 1.Keep furniture away from heat sources.
- 2.Do not clean furniture with harsh cleaner or polishes.Do not use detergents,solvents,abrasives,spray packs or leather cleaner. Use non-color mild soa with warm water to clean spills(Mix 1:10 soap to water).
- 3.Do not place furniture under direct sunlight,material will possibly fade over time.
- 4.Do not use on site dry cleaning machine.Children should not climb or jump on the furniture.
- 5.Do not write on furniture that is not protectedby a padded barrier.
- 6.Not for commercial use,only for residential use.

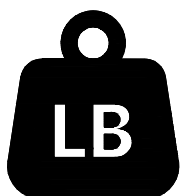

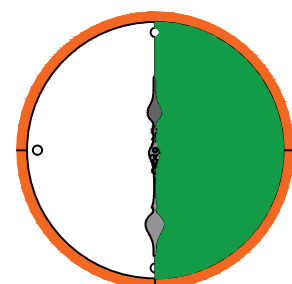

Weight Limitation
198 LBS





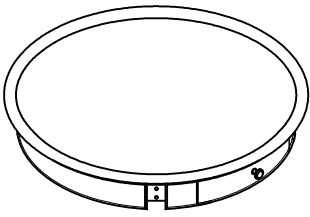

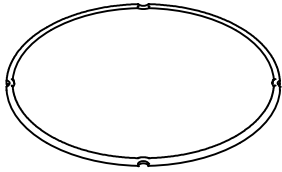
Around **30** min

PARTS LIST

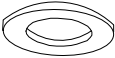
A	x1	B	x4	C	x1
					

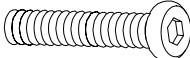
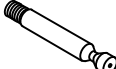

HARDWARE LIST

#1	x8	#2	x8	#3	x8	#4	x4	#5	x4
									
Ø1/4x20mm		Ø1/4x13mm		Ø1/4x2"		40mm		Ø5/8	

TOOL LIST

#6	x1
	
M4	

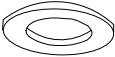
HARDWARE SPARE LIST

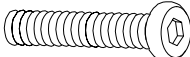
#1	x1	#2	x1	#3	x1
					
Ø1/4x20mm		Ø1/4x13mm		Ø1/4x2"	

ASSEMBLY INSTRUCTIONS

STEP- 1

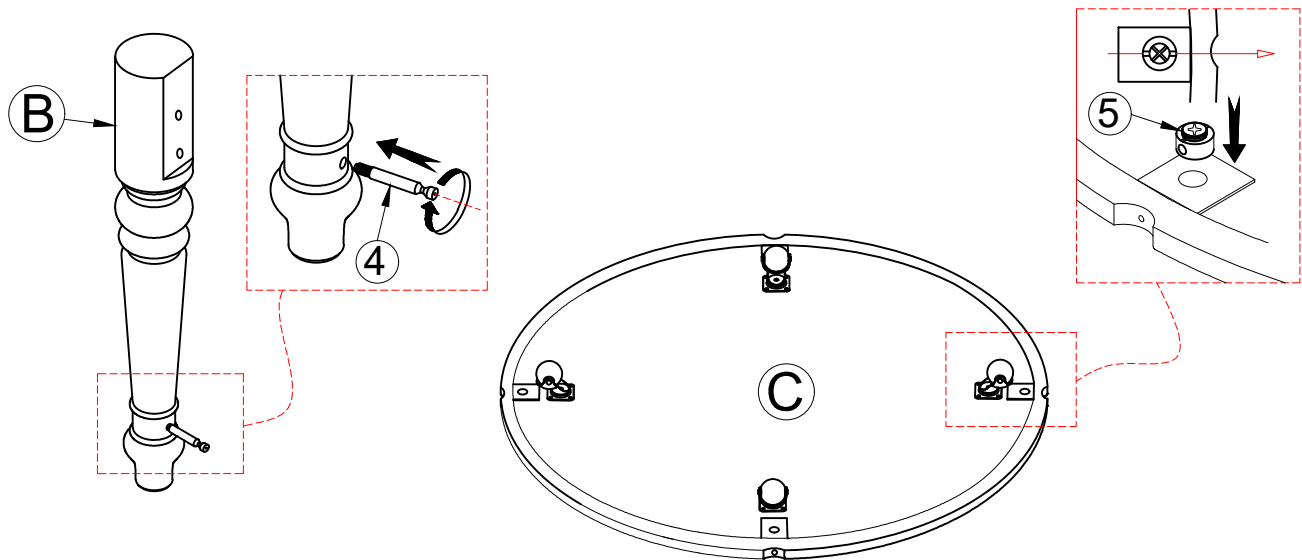

Attach Cam Bolt (4) on all the legs (B) and all Cam Lock Nut (5) on the bottom shelf (C).



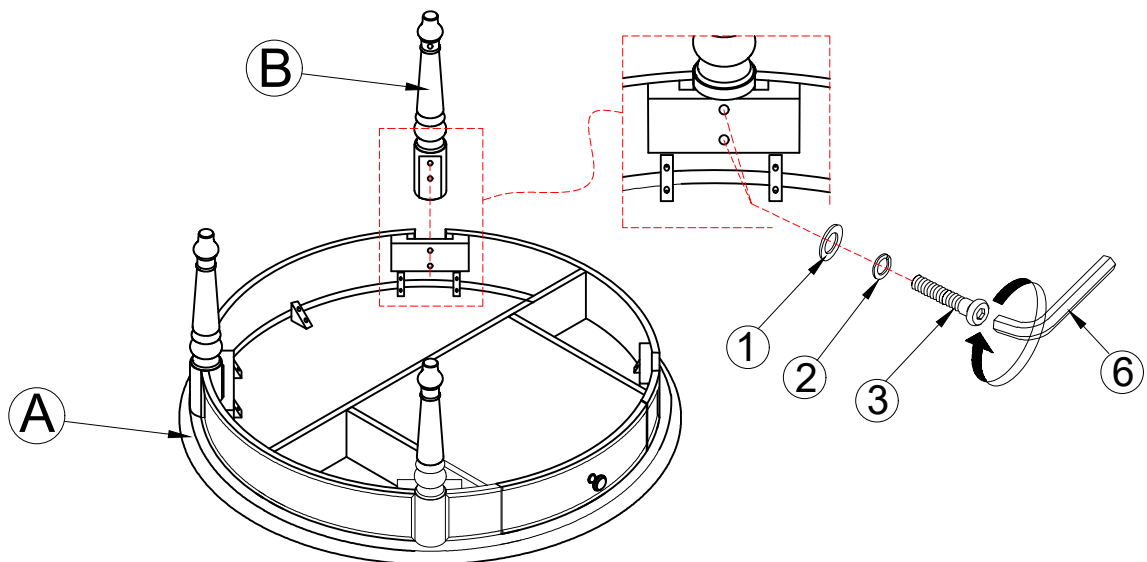

STEP- 2

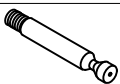
Attach leg (B) on the table top (A) by using Flat washer (1), Lock Washer (2), Bolt (3) with Allen Key (6) .(Don't tighten bolt until at step 4).

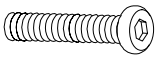

4		x4
5		x4
1		x6

2		x6
3		x6
6		x1

ASSEMBLY INSTRUCTIONS

STEP- 3

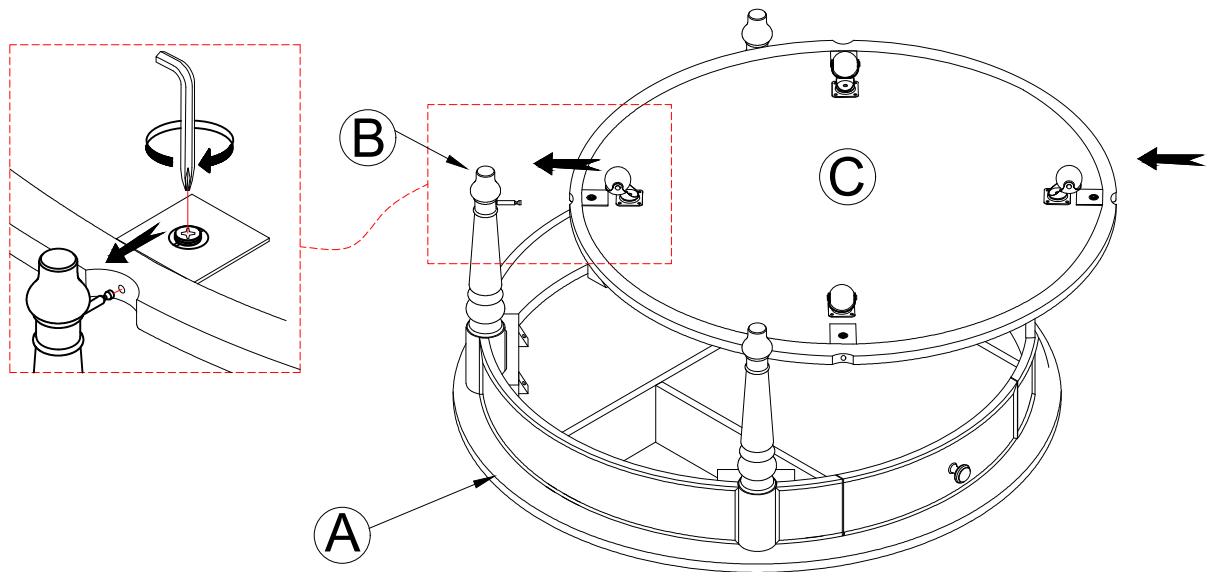

Attach bottom shelf (C) on the table top of step 2 .



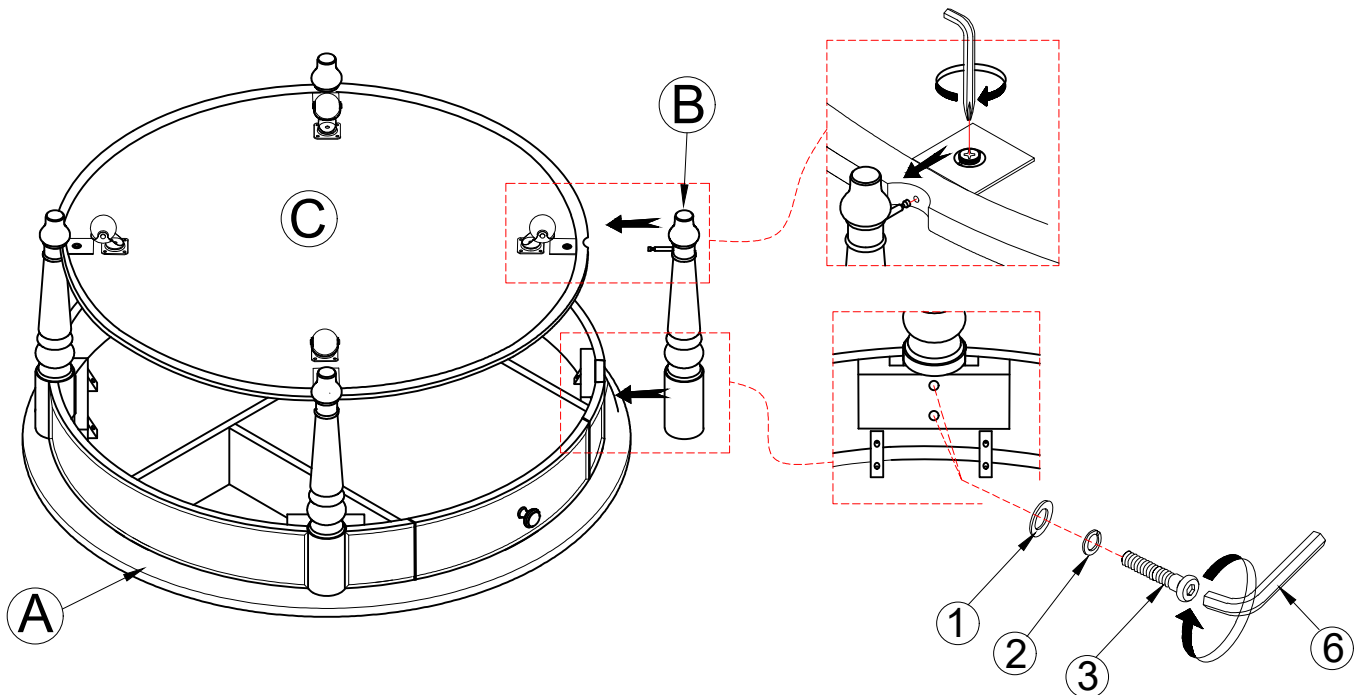

STEP- 4

Connect leg (B) and bottom shelf (C) to the table top of step 3 by using Flat washer (1), Lock Washer (2), Bolt (3) with Allen Key (6) .



1		x2
2		x2

3		x2
6		x1

 After installation, please keep the table balanced, tighten all bolts.

WARRANTY

1. We strive to offer high-quality products, and we also try our best to satisfy each and every customer that orders from us with product or service as needed.
2. We provide 30 days warranty starting from the time you receive the item. Each customer must provide a record of their order such as the order number, or item receipt for any items that are out of the warranty period you may also still receive.
3. Replacement parts by purchasing them with our company if they are available.

Are you having difficulty
With assembly? Missing parts?
Please send email with your order No to
customerservice@hulalahome.com
For return, please check the return policy with
the retailer or market place you bought from.

Appreciate your purchasing from us.
Pop up your life by our furniture piece!