

WORLD MARKET®

Assembly Instructions

TYLER BI-CAST OFFICE CHAIR





SKU 575119 / 542938



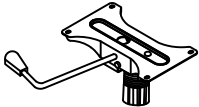

THANK YOU FOR YOUR PURCHASE. IF YOU HAVE ANY QUESTIONS
PERTAINING TO THE ASSEMBLY OF THIS FURNITURE PIECE, PLEASE CONTACT
THE NEAREST COST PLUS WORLD MARKET STORE.
IF YOU ARE NOT NEAR A STORE, PLEASE CALL OUR CUSTOMER SERVICE CALL
CENTER TOLL FREE AT 877- 967-5362 FOR ASSISTANCE.

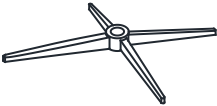
NOT FOR COMMERCIAL USE.

Component List

LABEL		DESCRIPTION	QTY
A		Seat	1
B		Lift Mechanism	1
C		Gas Lift	1
D		Base	1
E		Caster	4

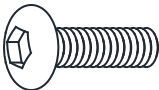
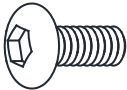
Hardware List

LABEL		DESCRIPTION	QTY
H-1		Large Allen Bolt 6x35mm	2
H-2		Small Allen Bolt 6x25mm	2
H-3		Spring Washer 6mm	4
H-4		Flat Washer 6mm	4

Tool List

LABEL		DESCRIPTION	QTY
T-1		Allen Key	1

Assembly Preparation

Before Beginning:

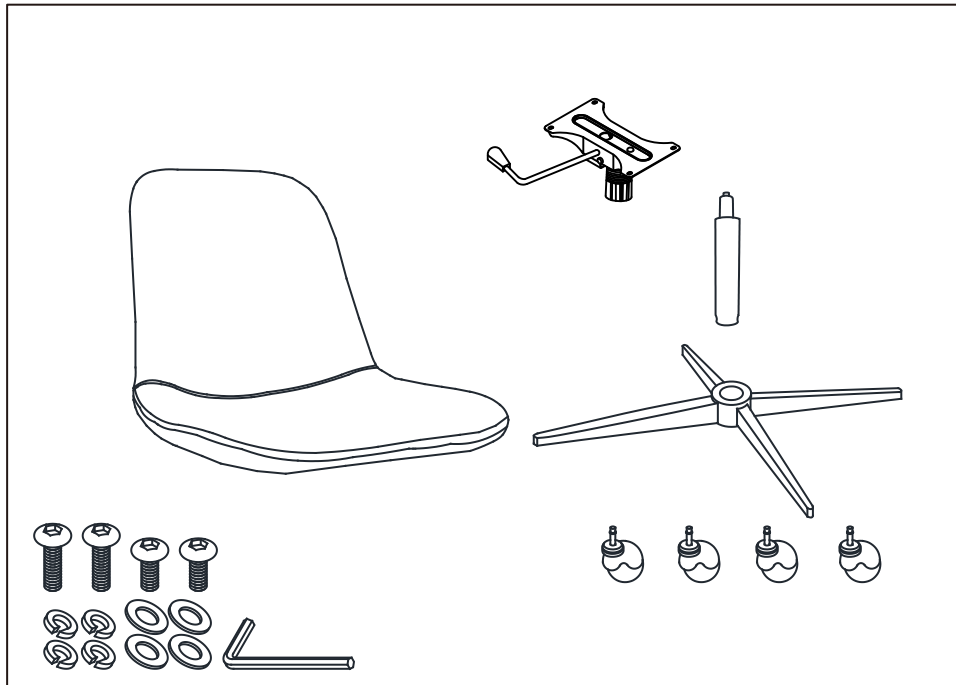

- Unpack all hardware bags and components to ensure you have all parts-



- Read instructions, cover to cover-



- Have 2 adults on hand for assembly-



- Do not assemble on flooring or carpet-



- Assemble on a clean non-marring surface (packing foam)-



- Save all packaging until finished-



- In case of missing parts, please contact your nearest Cost Plus World Market store or call our customer service call center at call 1-877-967-5362.

Assembly Steps

Step 1

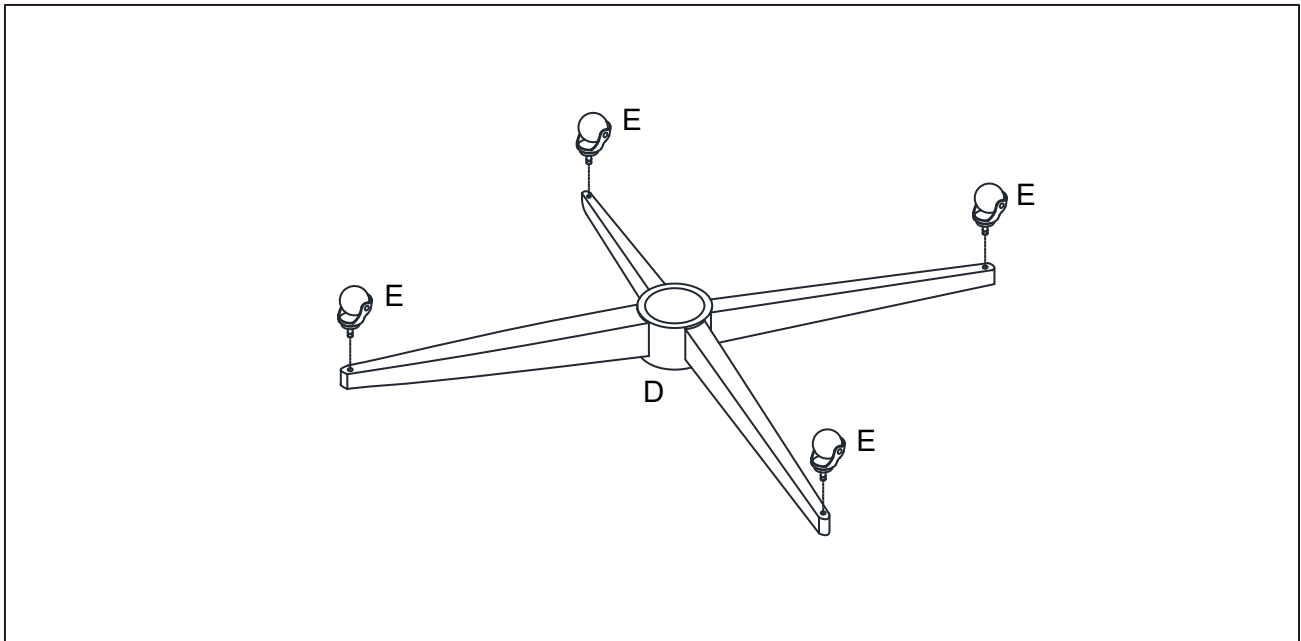

Insert Caster (E) to Base (D) as shown.

Step 2

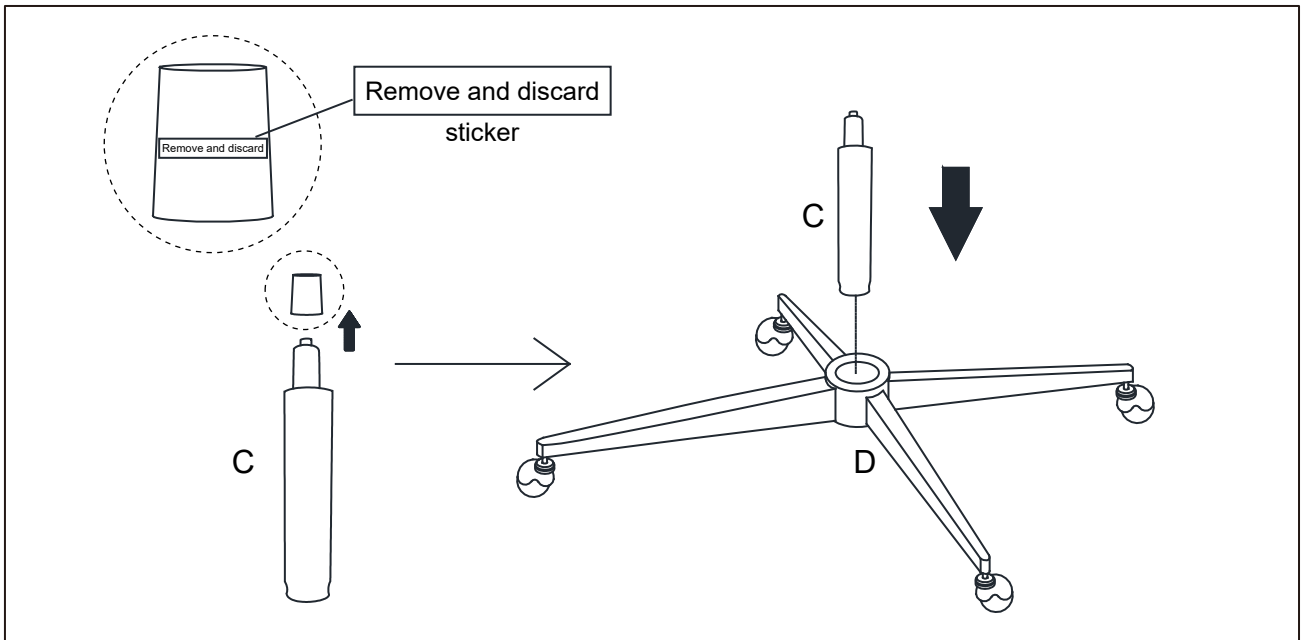

Remove and discard plastic cap from Gas Lift (C). Insert Gas Lift (C) into the center hole of Base (D) as shown.

Assembly Steps

Step 3

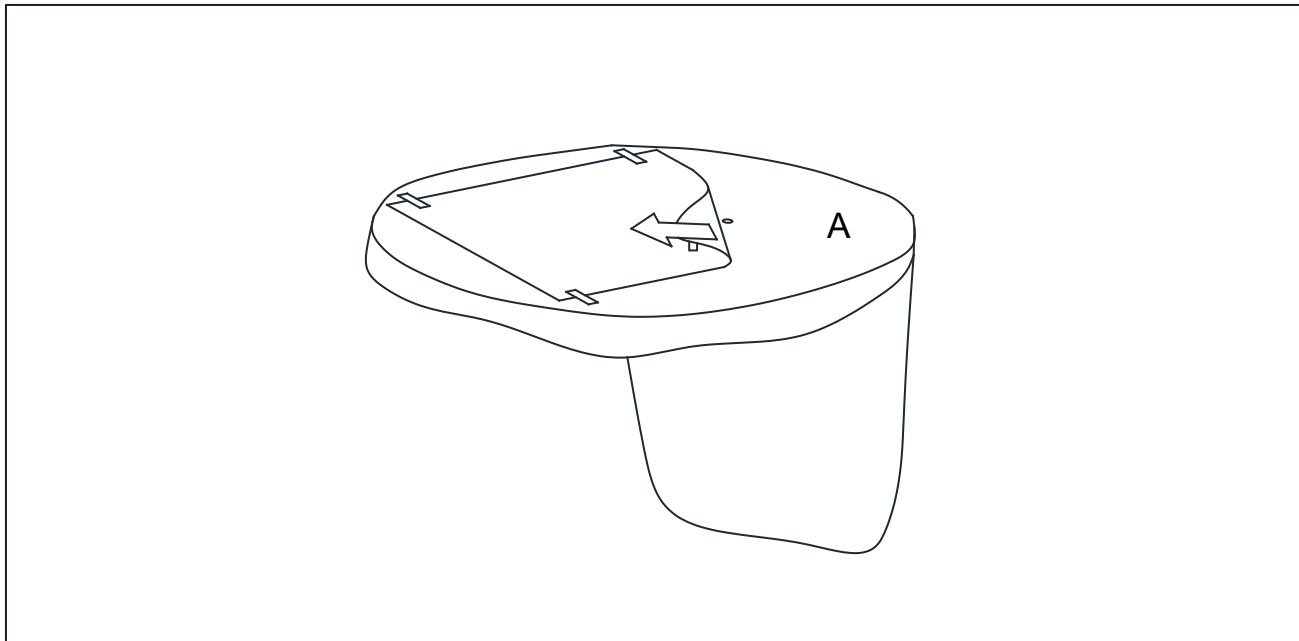

Carefully turn over Seat (A) so that the bottom is flat and faces upward as shown. Remove the protective sheet before attaching Lift Mechanism (B).

Step 4

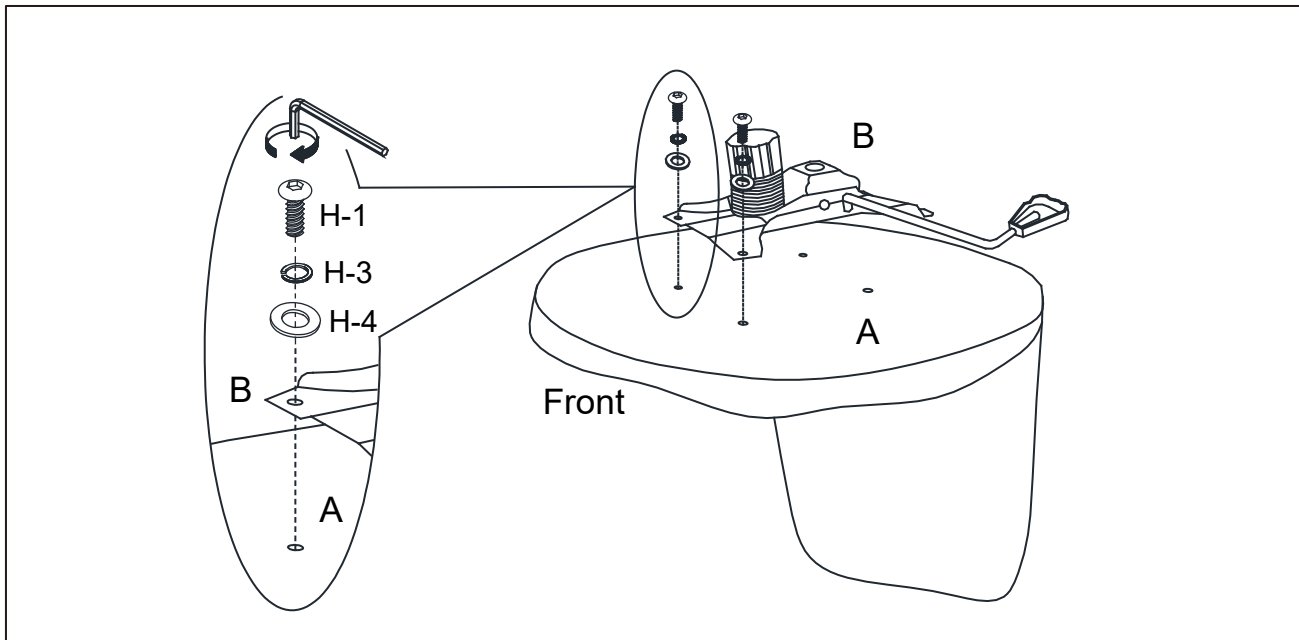

Align front holes on Lift Mechanism (B) to pre-threaded front holes on Seat (A). Attach the front of Lift Mechanism (B) using Large Allen Bolts (H-1), Spring Washers (H-3) and Flat Washers (H-4), stacking hardware in the order as shown. Engage Large Allen Bolts (H-1) using Allen Key (T-1) but do not fully tighten them until Step 5.

Assembly Steps

Step 5

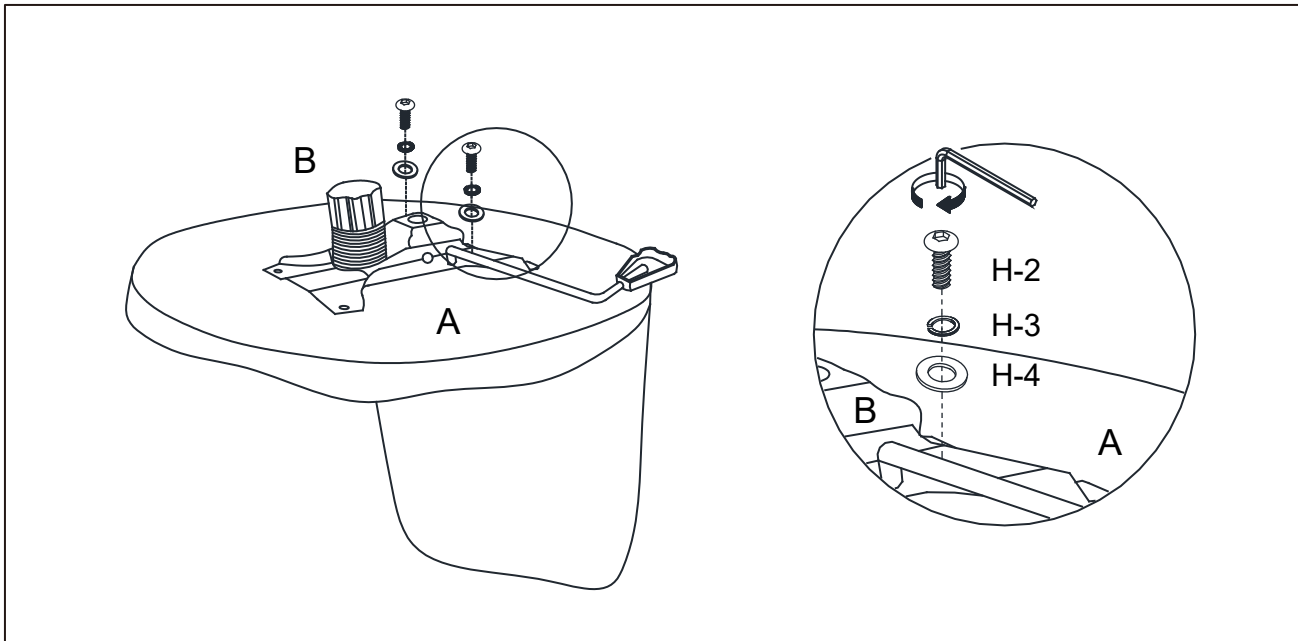

Align back holes on Lift Mechanism (B) to pre-threaded front holes on Seat (A). Attach the back of Lift Mechanism (B) using Small Allen Bolts (H-2), Spring Washers (H-3) and Flat Washers (H-4), stacking hardware in the order as shown. Fully tighten ALL Allen Bolts from Steps 4 and 5 using Allen Key (T-1).

Step 6

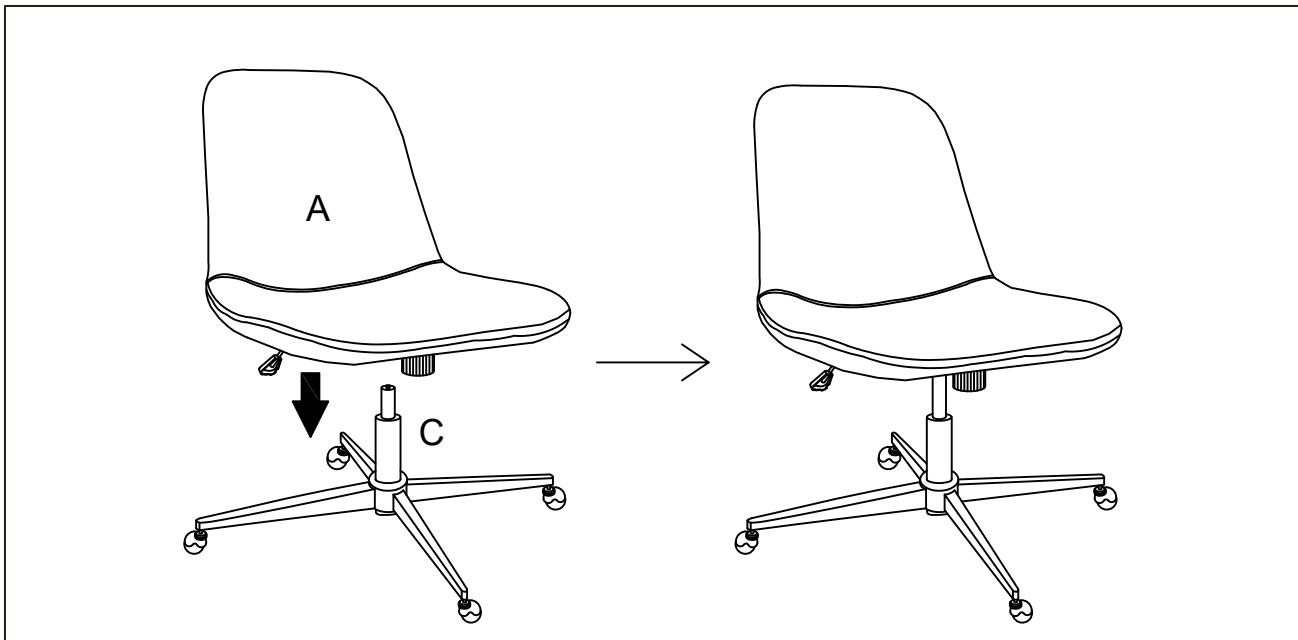

Position the Seat (A) facing down over the top of Gas Lift (C). Insert the Gas Lift (C) into the center hole of Lift Mechanism (B) and press down until fully engaged. The chair is now ready for use.

Operating Instructions

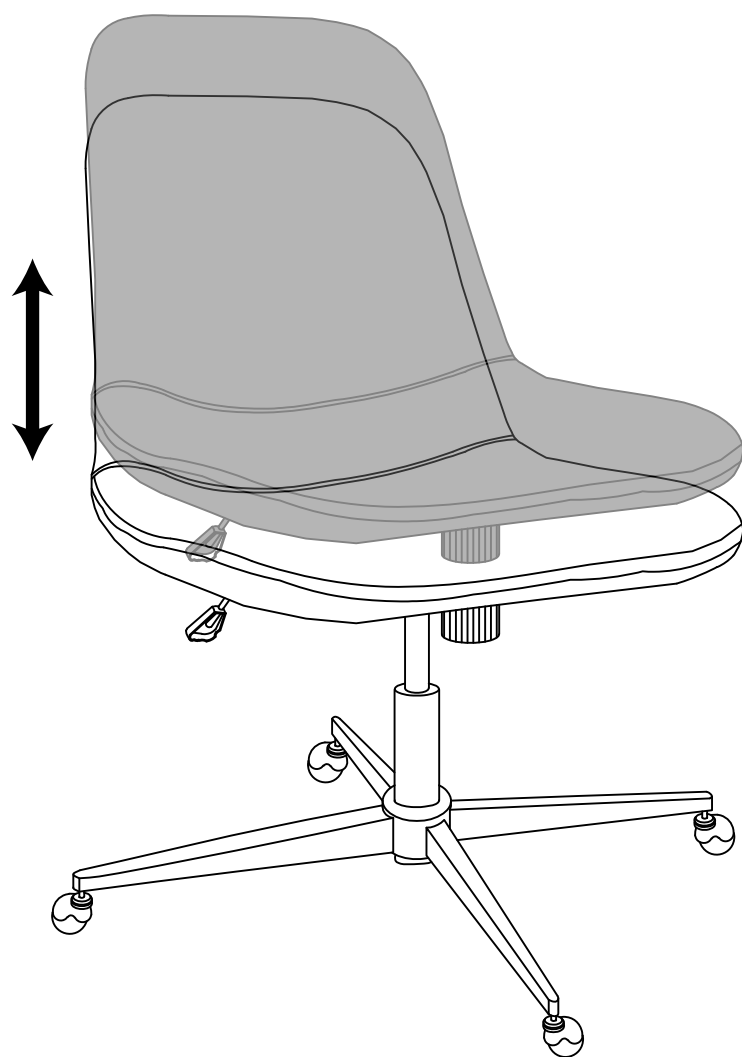

Function Instruction # 1

To Adjust Seat Height:

While seated, lean forward and reach under the right side of the chair to find the handle. Lift the handle and raise your body up slightly to allow the chair to rise to the desired height. Once desired height is reached, release handle to lock chair at desired height. To lower the seat, lift the handle while seated. The chair will descend until the handle is released or the chair reaches the bottom position.

Operating Instructions

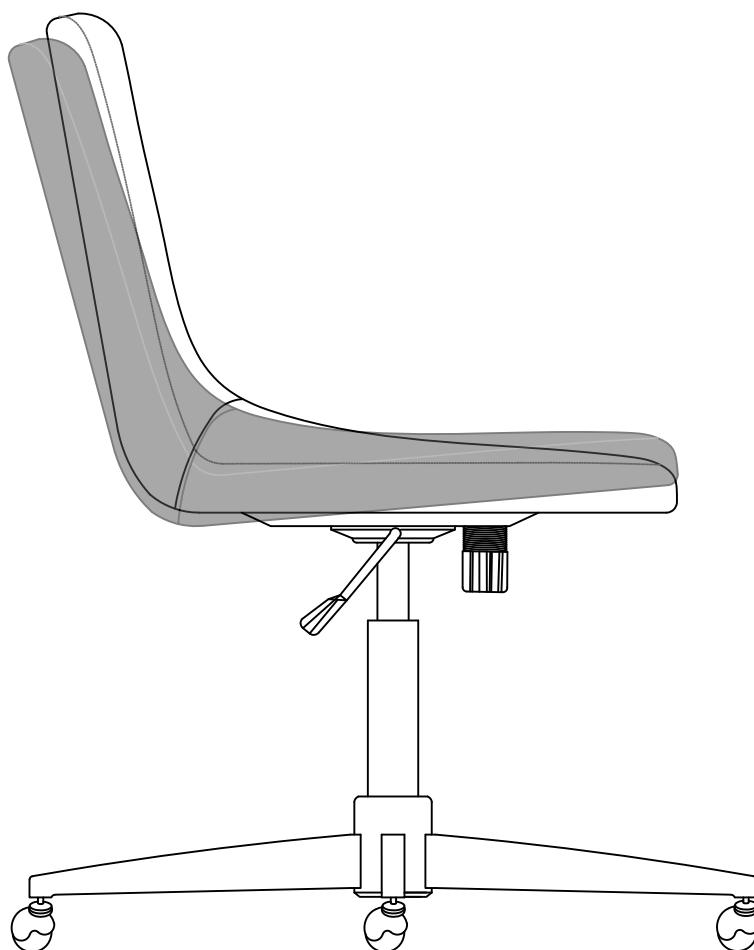

Function Instruction # 2

To Operate Tilt Lockout:

While seated, reach under the right side of the chair to find the height-adjustment handle. Pull the handle all the way out (away from the gas lift) to allow the chair to tilt backwards. To lock the chair in the upright or vertical position, sit upright and push the handle in towards the gas lift.

Operating Instructions

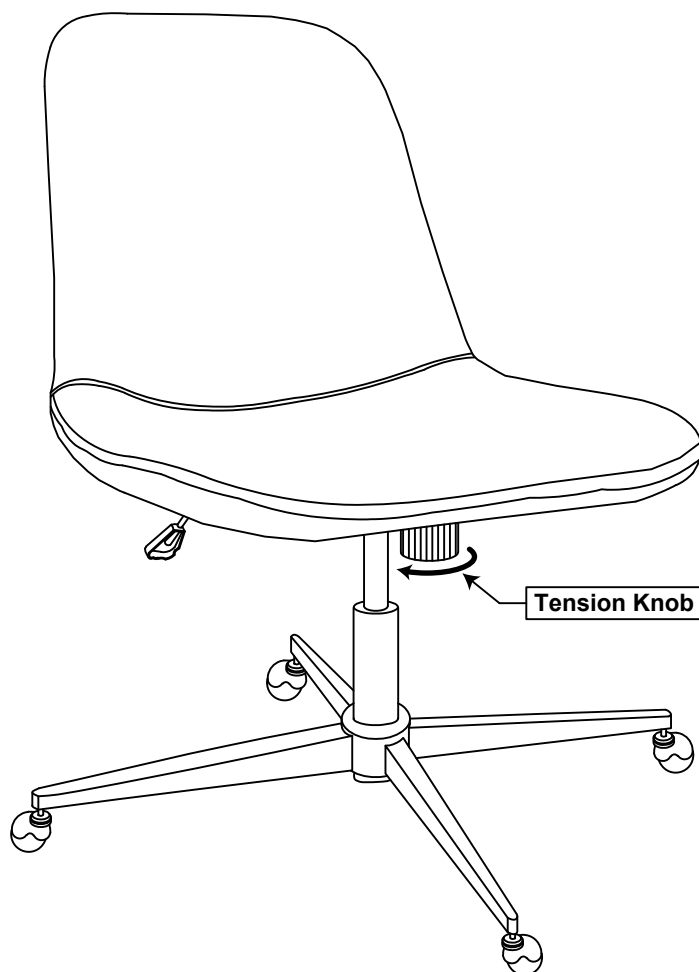

Function Instruction # 3

To Adjust Chair Reclining Tension:

From the seated position, reach under the front center of the chair, grasp the Tension Knob and turn it counter-clockwise to tighten the tilt mechanism for added tension. Turn the Tension Knob clockwise to loosen the tilt mechanism for less tension.

NOTE: Over-loosening the Tension Knob can cause unexpected chair recline when seated. Be aware of tension status before sitting.

Operating Instructions

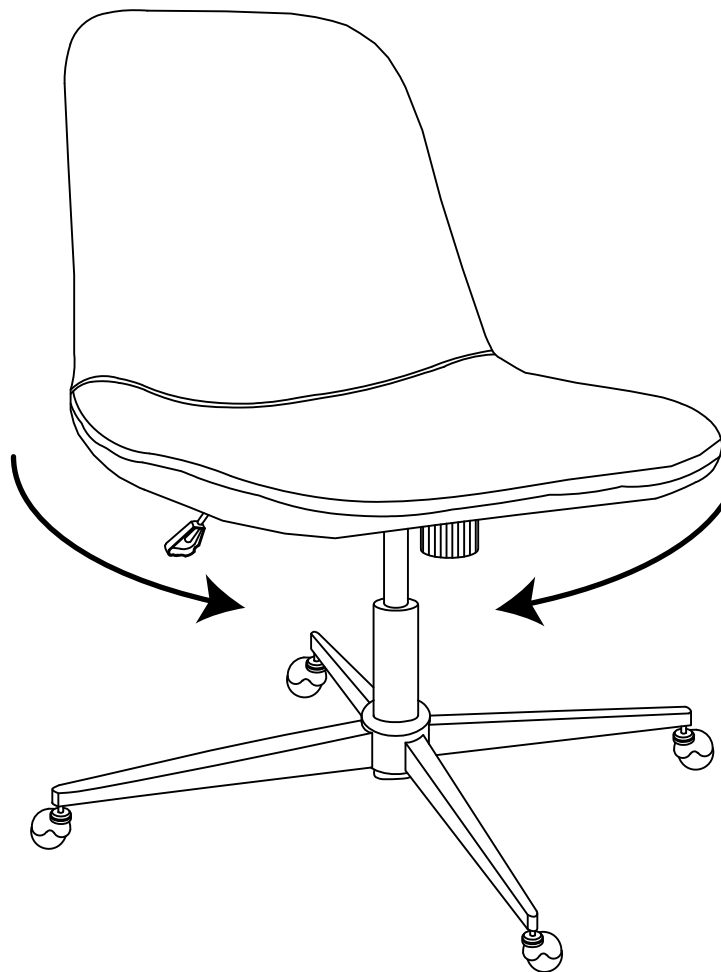

Function Instruction # 4

360-degree Swivel:

The chair swivels freely clockwise or counter-clockwise.

Care & Maintenance



- Do not put hot items directly on furniture surface.

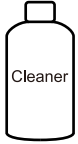

- Do not clean furniture with harsh cleansers or polish.

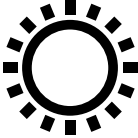

- Do not place furniture in direct sunlight.

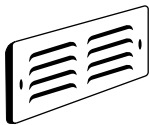

- Do not place furniture near heating or cooling vents.



- Do not write on furniture without a padded barrier to protect the surface.



- Do not place furniture outside. For indoor use only.



- Not for commercial use. For residential use only.

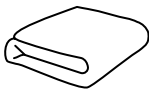

- Dust and pick-up spills using a clean, non-colored, lint-free, dry cloth.

WORLD MARKET®

LIMITED WARRANTY—Upholstered Furniture

For your satisfaction, this product has a limited one year (1) warranty from date of purchase.

The limited warranty covers:

1. **Material or Workmanship defects:** All defects related to fabric material (tears, fraying, crease marks, skip stitches or open seams) and wooden frames under normal household use.
2. **Manufacturing defects:** Support webbing material and “S” Springs defect or damage including method of attachment to wooden frame.
3. **Foam:** Loss of resiliency. The loss of resiliency should not be confused with softening and or flattening of fiber batting due to normal use.
4. **Cushions with enclosed steel pocket coils:** Failed or ruptured steel pocket coils enclosed inside seat cushions.
5. **Leather:** Tearing, splitting or cracking of material. The warranty does not cover natural markings, variations in the leather color or grain due to the authentic cowhide leather.
6. **Bonded Leather or Bi Cast Leather (PU):** Separation of the polyurethane coating, peeling or cracking of the inner layer.

This warranty does not cover:

1. Damage due to mishandling outside of its original protective packaging, abuse, negligence such as burns, pet damage, or treatment with chemical product, solvents, dyes, corrosive chemicals, inks, paints or harsh cleaning products.
2. Damage due to exposure to direct sunlight, fire, high heat, water, or any bright light source (natural or artificial) as well as cuts, punctures or ripped fabric due to abuse.

All claims for service must be accompanied by proof of purchase (Bill of Sale).

Any claim for service under the limited warranty is valid and applicable only to the original purchaser and must be processed through Cost Plus World Market.

This limited warranty is applicable to upholstered product purchased for (residential) home use only.

Product(s) purchased for commercial use will void all warranty claims as listed above.